

2023 年浙江省宁波市中考模拟英语试题

学校: _____ 姓名: _____ 班级: _____ 考号: _____

一、完形填空



I had lost my wallet. There was some money in it, but far more 1, there were two tickets to a World Cup football game in it!

My 2 gave me these as a special present. She worked for the organizers so she got the 3 as a special gift. What was I going to say to her? I searched for weeks, but nothing.

Months went by and I got a new wallet, but I didn't have the heart to tell my aunt that I had 4 the tickets. "Only two months left to the World Cup!" She counted down the days and she was very 5. It was terrible.

With less than a week until the World Cup was to start, I 6 it was time for me to confess (坦白).

I went over to her place. I guessed she could see that I was 7. "I need to tell you ... She stopped me. "Good, but before you do, I wonder if you know anybody else who might 8 some tickets to the big game! I have two more."

"This solves my problem!" I thought, so I didn't tell the 9.

"Sure," I said. "I can find someone to give them to." I took the tickets, 10 as I saw my aunt's smiling face, I could not lie any longer.

"Aunt Kathy, I lost the tickets," I said. She 11 me with an understanding smile and said, "I 12. Your mother told me. It's all right. I know how sad you felt about it. It was an 13. It could happen to anyone."

I could not believe that my aunt was so 14. She found two more tickets and gave them to me as if she didn't know I had lost my tickets.

"Now you can still take your best friend to the World Cup!" she laughed.

"Yes, and I'm taking 15," I looked at my favorite aunt and said.

- | | | | |
|-----------------|----------------|------------|------------|
| 1. A. strangely | B. importantly | C. clearly | D. greatly |
| 2. A. mother | B. aunt | C. friend | D. teacher |
| 3. A. tickets | B. footballs | C. money | D. wallets |
| 4. A. sold | B. brought | C. lost | D. got |

5. A. relaxed B. worried C. surprised D. excited
6. A. remembered B. promised C. realized D. explained
7. A. proud B. satisfied C. bored D. sad
8. A. have B. return C. want D. share
9. A. time B. story C. joke D. truth
10. A. or B. but C. and D. so
11. A. looked at B. looked after C. looked like D. looked for
12. A. imagine B. forget C. guess D. know
13. A. accident B. idea C. action D. excuse
14. A. honest B. polite C. good D. lucky
15. A. me B. you C. her D. them

二、阅读单选

A lot of sportspersons did an excellent job during the Tokyo 2020 Olympic Games. What is the key to success? Some excellent sportspersons and their coaches share advice from their experiences.

Missy Franklin, swimming	Never forget being nervous is an unbelievable thing. It shows that you really care about what you are doing. Do not fear your nerves (紧张). Accept them and turn them into your own super power. And then no one can stop you!
Brad Guzan, soccer	You have to accept difficulty and know that it won't last. I try to use it as a chance to improve. You should train harder and practice different skills of the game. Hard times make you stronger as a player and as a person.
Quan Hongchan, diving	“Born in a farming family, the 14-year-old diving girl, faced the hardship bravely, and she takes the most active part in training at her age,” her coach said. “Hard work pays off. Her perfect diving performance amazed the world. Besides, an AI training system also helped her train.”
Liu Yang, gymnastics	When training for a competition, train hard with your attention. The best results come from being fully prepared. That's true for a competition or for getting ready to take a test. During the whole training, do not forget to have fun.

Su Bingtian, 100m race	You won't know whether you can be better or not until you really get there. Now I've run faster than before, so I am sure that there is still room for improvement if I increase my speed in the final meters of races. I don't really agree that this is already the best score for Asian-born runners.
---------------------------	---

16. According to the passage, _____ uses an AI system to help train.
A. Missy Franklin
B. Quan Hongchan C. Liu Yang D. Su Bingtian

17. To Liu Yang, what is important when he is training?

- A. Prepare well and have fun. B. Train hard and be confident.
C. The AI training system and attitude. D. Work hard and do not fear nerves.

18. We can learn from the passage that _____.

- A. being nervous means you have much super power
B. practicing more skills makes you better than before
C. starting training at an early age leads to success easily
D. breaking world records is possible for Asian-born runners

“What’s the meaning of life?” This is a question we all ask ourselves at one point or another. The best answer that I came across was written by the great psychologist (心理学家), Viktor Frankle. He wrote that “The meaning of life is to give life meaning.”

When I was a young boy, I gave my life meaning by simply playing, running, jumping, swimming, laughing and riding my bike.

When I went to school, I gave my life meaning by learning, studying hard, getting good grades and trying to make my mom and dad proud.

When I was a teenager, I found meaning in playing sports and hanging out with my friends.

In college, I found my life meaning by deciding what I wanted to study and what job I would prepare for.

When I was working as a teacher, I found meaning in helping to open young minds to new ideas and old wisdom.

When I married and had kids, I found meaning in protecting and watching over those I loved. When I found out both of my sons were mentally handicapped (弱智的), I found meaning in loving them, caring for them and learning so much from them about life, love,

patience, faith and joy.

As I grew older, I began to understand meaning isn't something that comes and goes. We can give meaning to every moment of our lives. We can bring meaning to the thoughts we have. We can bring meaning to the things we do. We can bring meaning to the hearts we touch. All we have to do is to love.

It is love that makes life worth living. It is love that gives life meaning.

19. The underlined phrase "came across" in Paragraph 1 probably means _____.
- A. met B. trusted C. spread D. kept
20. From the passage, we know the writer used to be _____.
- A. a teacher B. a sportsman C. a writer D. a psychologist
21. In which way does the writer show the opinion?
- A. By listing numbers. B. By asking questions.
C. By comparing the facts. D. By sharing his stories.
22. The best title for the passage might be _____.
- A. My Life Skills B. My Life Story
C. The Meaning of Life D. The Love for Children



Once upon a time, a king went on a visit to neighboring kingdoms. He was gifted a pair of baby macaw parrots, a red one and a blue one, by the king of the last kingdom that he visited. They were the most beautiful birds he had ever seen. So, after returning to his kingdom, he called for a bird trainer and asked him to train the macaw parrots.

The king also set a place in the palace garden for the parrots. He often looked at them from his palace window. One day, the trainer came to the palace and told the king that the red parrot was flying high in the sky. However, the other one was not moving from his branch (树枝) since the day he had arrived from the last kingdom the king visited.

Hearing this, the king sent for other trainers from the nearby kingdoms. They all tried their best, but couldn't make the parrot fly! The parrot was not moving from his branch at all. Finally, after trying everything, the king thought that maybe he needed

someone who might know their nature well. He asked a courtier (大臣) to get a farmer from the countryside and take him to the parrot to see if he could solve the problem.

The next morning, the king was excited to see the parrot flying high above the palace garden. He asked his courtier to call that farmer to meet him. The courtier hurried to call the farmer, who came and stood before the king. The king asked him, “How did you make the parrot fly?”

With his hands folded politely, the farmer said to the king, “It was very easy, my king. I simply cut the branch where the bird was sitting.”

23. Where were the parrots from?

- | | |
|-----------------|-----------------------------|
| A. The trainer. | B. The palace garden. |
| C. The farmer. | D. The neighboring kingdom. |

24. The underlined word “he” in Paragraph 2 refers to _____.

- | | | | |
|-------------|----------------|--------------------|-------------------|
| A. the king | B. the trainer | C. the blue parrot | D. the red parrot |
|-------------|----------------|--------------------|-------------------|

25. Which is the best place for the sentence “He even asked many other people to try to make the parrot fly but they all failed.”?

- | | | | |
|-----------------------------|-----------------------------|-----------------------------|-----------------------------|
| A. <input type="checkbox"/> | B. <input type="checkbox"/> | C. <input type="checkbox"/> | D. <input type="checkbox"/> |
|-----------------------------|-----------------------------|-----------------------------|-----------------------------|

26. What lesson can we learn from the passage?

- A. Stay away from strangers and protect yourself.
- B. Think carefully about what to say and what to do.
- C. Working hard will make you happy and successful.
- D. Stepping out of comfortable situation helps you grow.

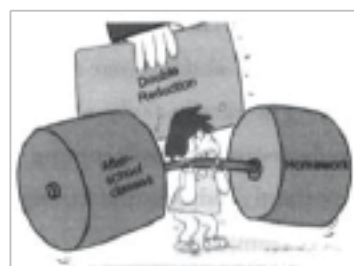

In 2021, China’s education system announced a new “Double Reduction” policy (“双减”政策). “Double Reduction” refers to a reduction in the total amount and time of school homework and a reduction of after-school classes.

“The policy really helps me,” Shen Yuzhe, a 13-year-old boy from Beijing said. He is happy that he has less homework than before and he can finish it at school with no need to take it home. “I’m also happy to find there are fewer exams. Besides, teachers now teach at a much slower pace so that we have enough time to understand what we have learned. We don’t

need to buy workbooks anymore and the exercises are mainly from the textbook,” Shen Yuzhe said.

“The best thing about the ‘Double Reduction’ is the increased time in after-school activities such as dancing, volleyball and drama. Zhang Hangming from Tianjin is also excited. He has joined a group called “Leadership Development”, learning all kinds of useful skills. He likes it because teachers are also giving them more chances to learn from real life. For example, they went to research plants in a field during a science class. He believes that is a much better way to learn than just studying the books.

Some people welcome the policy while others are still worried. Yu Zhiyue, a middle school student in Jiangsu, still feels tired. “With the ‘Double Reduction’, I have really got less homework to do. But my mother is worried that I will lose the chance to review what I’ve learned in class without enough homework. So I have lots of after-school classes. Since I can only take these classes on weekdays now, weekdays have become especially long and tiring for me. From Monday to Friday, I need to take online classes at home after I come back from school,” she said. “My parents told me the rules had changed but the competition had not gone away.”

27. Shen Yuzhe likes the policy because _____.
- A. he has less homework and fewer exams B. he has more after-school activities
 C. he takes after-school classes on weekdays D. he has chances to learn from real life
28. Yu Zhiyue’s mother may agree that _____.
- A. children should have time to relax B. it’s better to learn by reading books
 C. children still need to study very hard D. it’s important to develop useful skills
29. The purpose of the passage is mainly to _____.
- A. show the influence of the policy on students B. introduce the importance of the policy
 C. explain the reason why the policy is popular D. encourage students to do less homework

30. Which of the following shows the structure of the passage?

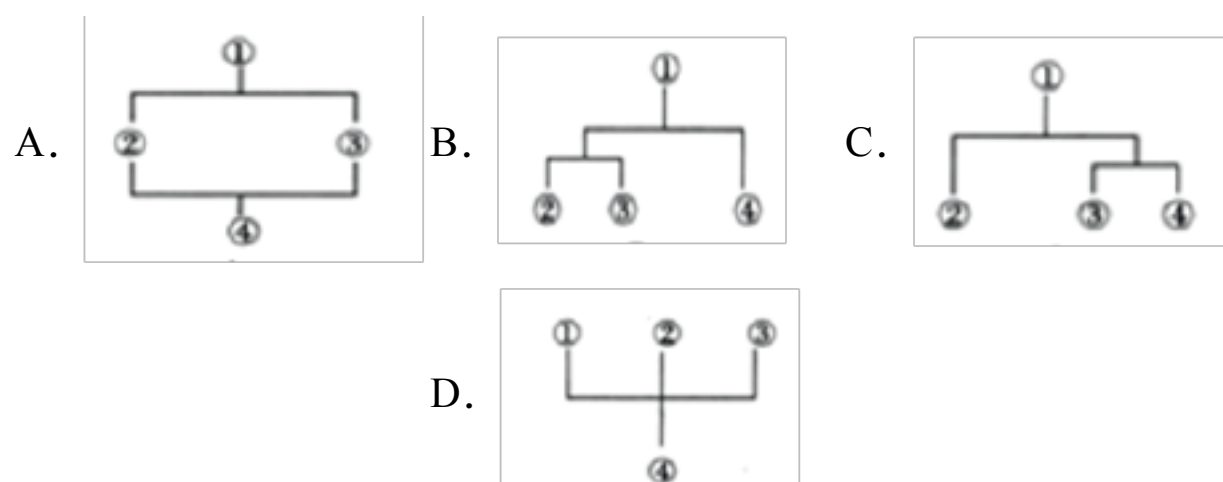

三、阅读还原 6 选 5

It is said that the eyes are the windows to our soul. However, to have healthy eyes, you have to look after them properly. Your eyes need everyday attention.

31. Eat more fresh fruit, vegetables, fish, eggs and milk. It's good for your eyes. Also, a regular amount of vitamins A and B2 should also be taken.

32. This relaxes the eye muscles(肌肉) and gives them the rest they need. Sleep can help the body repair its tired tissue(组织). You should sleep for at least seven to eight hours every day. Loss of sleep can give you dark circles under your eyes.

33. Blink(眨眼) your eyes at regular periods to keep your eyes moist(湿润的).

34. For example, if you get something in your eye, don't start rubbing(揉)it. Rubbing is harmful to your eyes. Don't read or write in poor or bright sunlight because sunlight can cause eye tiredness. Remember to use sunglasses to stop the sun from shining directly in your eyes.

35. Too much reading, writing, watching television or working on a computer can also cause eye tiredness, so you need to rest after you work for too long.

- A. Exercise your eyes regularly
- B. Have enough and sound sleep
- C. Keep away from the screens
- D. Pay more attention to your diet
- E. Treat your eyes correctly
- F. Rests are required after working for too long

四、根据汉语提示填空

36. In _____ (三月), the third month of the year, it's always very cold in my hometown.

37. Tony often _____ (借) my dictionary, but he never remembers to return it to me.

38. We take great _____ (骄傲) in offering the best service around the world.

39. Jane is _____ (疯狂的) about reading and this is the eleventh book she has read this month.

40. Big cities can be lonely places if you have no friends or _____ (亲戚) there.

41. David goes to work by bike every day to _____ (避免) the rush hour and get some exercise.

42. I guess the temperature is _____ (在.....下面) zero because it's freezing here.

43. Jim always seems to know _____ (确切地) what to get people as gifts.

44. You should always knock at the door before _____ (进去) others' rooms.

五、根据首字母填空

45. After the candles were b _____ out, we could finally eat the birthday cake.

六、短文选词填空

用方框中所给单词的适当形式填空，每词仅用一次（每空一词）。

for	daughter	active	plan	young
-----	----------	--------	------	-------

Until recently, Ajayi had never gone to school. Now at the age of fifty, she attends a school in Ilorin Nigeria, wearing the same pink dress as the other two hundred girls at the school. She studies with the students nearly forty years 46 than her. Ajayi runs her own business making and selling bags, but she believes it is still necessary 47 her to learn to read and write. In class, she answers questions 48. She plays, talks and discusses together with her classmates. She is good at cooking. Children all like the food she makes. They enjoy themselves at school.

Ajayi's 49 used to feel embarrassed about their mother's attending school with children. But now, they choose to support her efforts.

Ajayi 50 to continue her education for four more years. She says it will help her business.

七、语法填空

阅读下面短文，在空白处填入一个适当的词，或填入括号中所给单词的正确形式。

Chinese Doctors is a movie that can bring tears to everyone's eyes. Based on real events, the movie retells China's fight 51 COVID-19 in Wuhan, the city hit by the pandemic at the beginning of 2020.

With 52 close look at the medical workers and patients in Wuhan during the pandemic, the movie centers on a hospital president. And two other doctors from Shanghai and Guangdong hurried to Wuhan 53 (offer) a helping hand.

The leading role in the movie is Zhang Jingyu. The actor who played the role recalls that he once stayed with Zhang Jingyu to watch him closely while he was working. It made his performance much 54 (successful).

The film workers entered Wuhan soon 55 the city reopened its door in early April 2020. They were looking 56 to getting first-hand information from front-line medical workers. Of course, they 57 (strict) followed the pandemic prevention guidelines

while making the movie. For example, all the members took COVID-19 tests every two weeks and the tools 58 (clean) every day. There are many breathtaking moments in the movie, such as an infected (感染的) woman giving birth to 59 (she) baby and the use of ECMO for badly infected patients.

“The movie truly shows the anti-epidemic situation in Wuhan, draws a picture of the whole country overcoming so many 60 (difficulty) together, and most importantly, shows the strength of China, said Zhong Nanshan, head of China’s COVID-19 expert team.

八、材料作文

61. 假如你是李华，最近，某英文网站正在举办以“A Person I Will Never Forget”为主题的征文活动。请你根据以下思维导图提示，先补全标题“I Will Never Forget”，并写一篇英语短文参加此次征文活动。

注意：(1)短文必须包括思维导图的所有要点，并适当发挥；

(2)文中不得出现真实的人名和校名；

(3)词数 80-100。

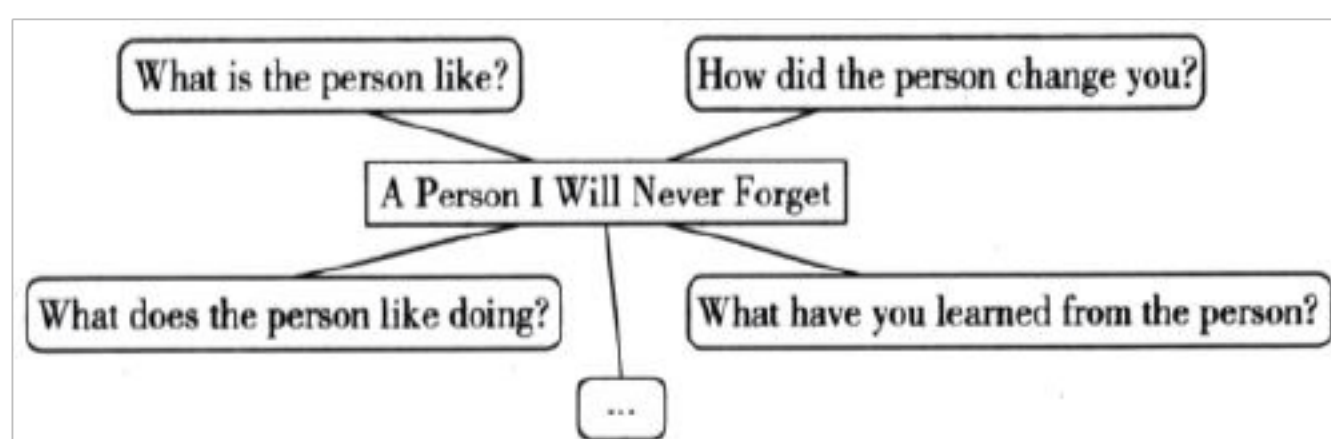

I Will Never Forget _____

参考答案：

1. B
2. B
3. A
4. C
5. D
6. C
7. D
8. C
9. D
10. B
11. A
12. D
13. A
14. C
15. B

【解析】

【导语】

本文讲述了作者丢了姑妈给的两张世界杯足球赛的门票，她的姑妈又给了她两张。

1.

句意：它里面有一些钱，但是更重要的是，里面有两张世界杯足球赛的门票！

strangely 奇怪地； importantly 重要地； clearly 清楚地； greatly 极大地。根据“there were two tickets to a World Cup football game in it!”可知，钱包里有两张世界杯门票，因此是更重要的事，故选 B。

2.

句意：我的姑妈给我这些门票作为一个特殊的礼物。

mother 母亲； aunt 姑妈； friend 朋友； teacher 教师。根据后文的“but I didn't have the heart to tell my aunt that I had ... the tickets.”可知，我的姑妈给我的这些门票，故选 B。

3.

句意：她为主办单位工作，所以她得到这个门票作为一个特殊的礼物。

以上内容仅为本文档的试下载部分，为可阅读页数的一半内容。如要下载或阅读全文，请访问：<https://d.book118.com/807051041044006054>