



# Implementing IPv6 over MPLS

---

**Last Updated: November 15, 2011**

Multiprotocol Label Switching (MPLS) is deployed by many service providers in their IPv4 networks. Service providers want to introduce IPv6 services to their customers, but changes to their existing IPv4 infrastructure can be expensive and the cost benefit for a small amount of IPv6 traffic does not make economic sense. Several integration scenarios have been developed to leverage an existing IPv4 MPLS infrastructure and add IPv6 services without requiring any changes to the network backbone. This document describes how to implement IPv6 over MPLS.

- [Finding Feature Information, page 1](#)
- [Prerequisites for Implementing IPv6 over MPLS, page 1](#)
- [Information About Implementing IPv6 over MPLS, page 2](#)
- [How to Implement IPv6 over MPLS, page 5](#)
- [Configuration Examples for IPv6 over MPLS, page 13](#)
- [Where to Go Next, page 15](#)
- [Additional References, page 15](#)
- [Feature Information for Implementing IPv6 over MPLS, page 17](#)

## Finding Feature Information

Your software release may not support all the features documented in this module. For the latest feature information and caveats, see the release notes for your platform and software release. To find information about the features documented in this module, and to see a list of the releases in which each feature is supported, see the Feature Information Table at the end of this document.

Use Cisco Feature Navigator to find information about platform support and Cisco software image support. To access Cisco Feature Navigator, go to [Cisco Feature Navigator](#). An account on [Cisco.com](#) is not required.

## Prerequisites for Implementing IPv6 over MPLS

- This module assumes that you are familiar with IPv4. Refer to the publications referenced in the [Prerequisites for Implementing IPv6 over MPLS, page 1](#) section for IPv4 configuration and command reference information.



---

Americas Headquarters:  
Cisco Systems, Inc., 170 West Tasman Drive, San Jose, CA 95134-1706 USA

- Before the IPv6 Provider Edge Router over MPLS (6PE) feature can be implemented, MPLS must be running over the core IPv4 network. If Cisco routers are used, Cisco Express Forwarding or distributed Cisco Express Forwarding must be enabled for both IPv4 and IPv6 protocols. This module assumes that you are familiar with MPLS.

## Information About Implementing IPv6 over MPLS

- [Benefits of Deploying IPv6 over MPLS Backbones, page 2](#)
- [IPv6 over a Circuit Transport over MPLS, page 2](#)
- [IPv6 Using Tunnels on the Customer Edge Routers, page 3](#)
- [IPv6 on the Provider Edge Routers \(6PE\), page 3](#)

## Benefits of Deploying IPv6 over MPLS Backbones

IPv6 over MPLS backbones enables isolated IPv6 domains to communicate with each other over an MPLS IPv4 core network. This implementation requires only a few backbone infrastructure upgrades and no reconfiguration of core routers because forwarding is based on labels rather than the IP header itself, providing a very cost-effective strategy for the deployment of IPv6.

Additionally, the inherent Virtual Private Network (VPN) and MPLS traffic engineering (MPLS-TE) services available within an MPLS environment allow IPv6 networks to be combined into IPv4 VPNs or extranets over an infrastructure supporting IPv4 VPNs and MPLS-TE.

## IPv6 over a Circuit Transport over MPLS

Using any circuit transport for deploying IPv6 over MPLS networks has no impact on the operation or infrastructure of MPLS, and requires no configuration changes to the core or provider edge routers. Communication between the remote IPv6 domains runs native IPv6 protocols over a dedicated link, where the underlying mechanisms are fully transparent to IPv6. The IPv6 traffic is tunneled using the Any Transport over MPLS (MPLS/AToM) or Ethernet over MPLS (EoMPLS) feature with the routers connected through an ATM OC-3 or Ethernet interface, respectively.

The figure below shows the configuration for IPv6 over any circuit transport over MPLS.

**Figure 1** IPv6 over a Circuit Transport over MPLS

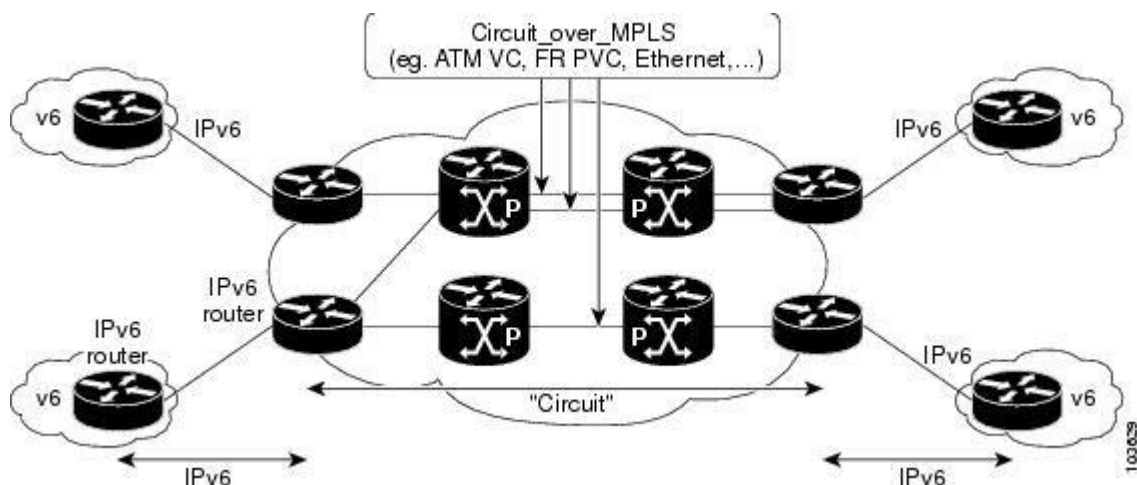



Reservation Protocol (RSVP). TDP and LDP can both be used for label distribution, but RSVP is used only in the context of MPLS-TE label exchange. The bottom label, automatically assigned to the IPv6 prefix of the destination, is distributed by multiprotocol BGP and used at each 6PE egress router for IPv6 forwarding.

In the figure below the 6PE routers are configured as dual stack routers able to route both IPv4 and IPv6 traffic. Each 6PE router is configured to run LDP, TDP, or RSVP (if traffic engineering is configured) to bind the IPv4 labels. The 6PE routers use multiprotocol BGP to exchange reachability information with the other 6PE devices within the MPLS domain, and to distribute aggregate IPv6 labels between them. All 6PE and core routers--P routers in Figure 3--within the MPLS domain share a common IPv4 Interior Gateway Protocol (IGP) such as Open Shortest Path First (OSPF) or Integrated Intermediate System-to-Intermediate System (IS-IS).

**Figure 3** 6PE Router Topology

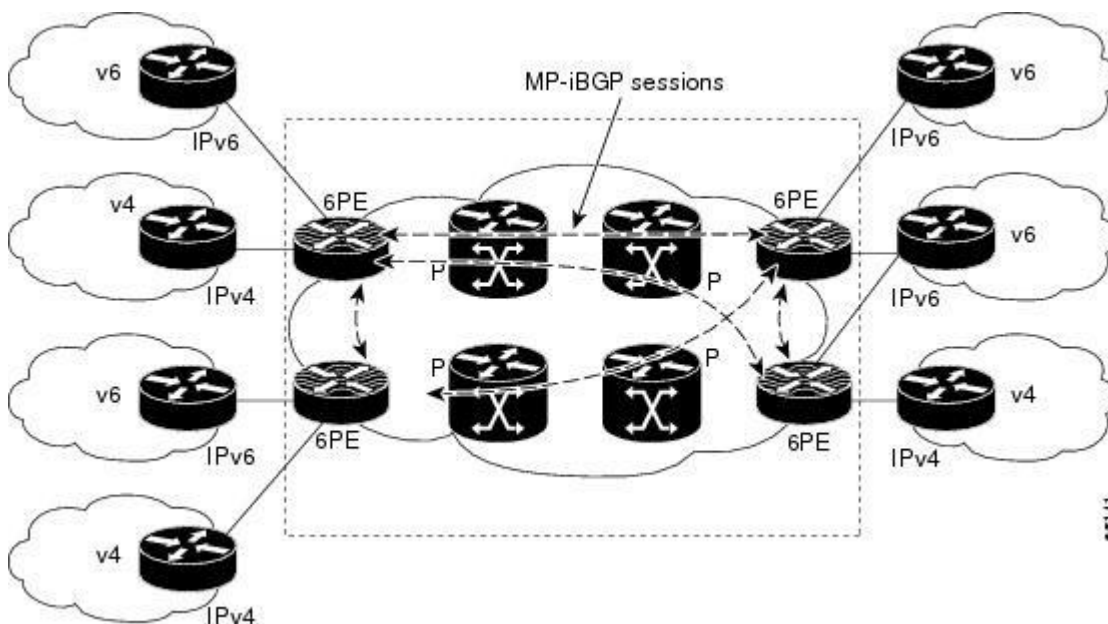

The interfaces on the 6PE routers connecting to the CE router can be configured to forward IPv6 traffic, IPv4 traffic, or both types of traffic depending on the customer requirements. 6PE routers advertise IPv6 reachability information learned from their 6PE peers over the MPLS cloud. Service providers can delegate an IPv6 prefix from their registered IPv6 prefixes over the 6PE infrastructure; otherwise, there is no impact on the CE router.

The P routers in the core of the network are not aware that they are switching IPv6 packets. Core routers are configured to support MPLS and the same IPv4 IGP as the PE routers to establish internal reachability inside the MPLS cloud. Core routers also use LDP, TDP, or RSVP for binding IPv4 labels. Implementing the Cisco 6PE feature does not have any impact on the MPLS core devices.

Within the MPLS network, IPv6 traffic is forwarded using label switching, making the IPv6 traffic transparent to the core of the MPLS network. No IPv6 over IPv4 tunnels or Layer 2 encapsulation methods are required.

- [6PE Multipath, page 5](#)

## 6PE Multipath

Internal and external BGP multipath for IPv6 allows the IPv6 router to load balance between several paths (for example, the same neighboring autonomous system or subautonomous system, or the same metric) to reach its destination. The 6PE multipath feature uses multiprotocol internal BGP (MP-iBGP) to distribute IPv6 routes over the MPLS IPv4 core network and to attach an MPLS label to each route.

When MP-iBGP multipath is enabled on the 6PE router, all labeled paths are installed in the forwarding table with MPLS information (label stack) when MPLS information is available. This functionality enables 6PE to perform load balancing.

## How to Implement IPv6 over MPLS

- [Deploying IPv6 over a Circuit Transport over MPLS](#), page 5
- [Deploying IPv6 on the Provider Edge Routers \(6PE\)](#), page 5
- [Verifying 6PE Configuration and Operation](#), page 10

## Deploying IPv6 over a Circuit Transport over MPLS

To deploy IPv6 over a circuit transport over MPLS, the IPv6 routers must be configured for IPv6 connectivity. Refer to [Implementing IPv6 Addressing and Basic Connectivity](#) for details on basic IPv6 configuration. The MPLS router configuration requires AToM configuration or EoMPLS configuration.

## Deploying IPv6 on the Provider Edge Routers (6PE)

- [Specifying the Source Address Interface on a 6PE Router](#), page 5
- [Binding and Advertising the 6PE Label to Advertise Prefixes](#), page 7
- [Configuring iBGP Multipath Load Sharing](#), page 9

## Specifying the Source Address Interface on a 6PE Router

Two configuration tasks using the network shown in the figure below are required at the 6PE1 router to enable the 6PE feature.

The customer edge router--CE1 in the figure below--is configured to forward its IPv6 traffic to the 6PE1 router. The P1 router in the core of the network is assumed to be running MPLS, a label distribution protocol, an IPv4 IGP, and Cisco Express Forwarding or distributed Cisco Express Forwarding, and does not require any new configuration to enable the 6PE feature.

**Figure 4** 6PE Configuration Example

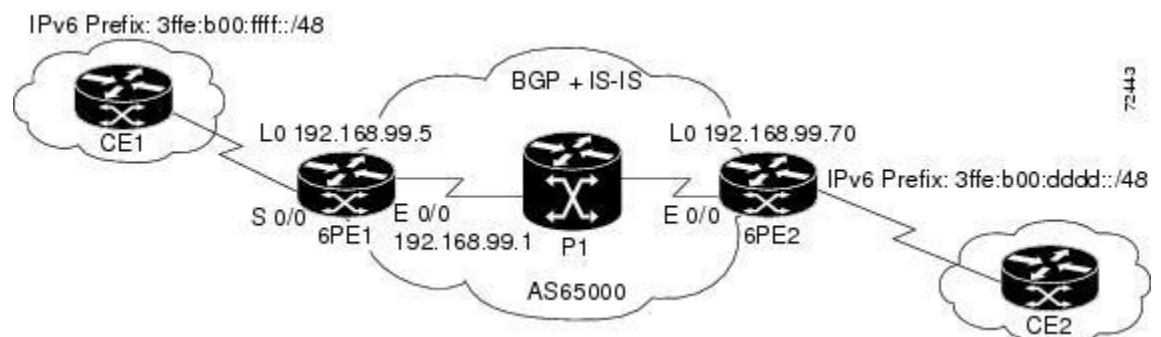

- The 6PE routers--the 6PE1 and 6PE2 routers in the figure below--must be members of the core IPv4 network. The 6PE router interfaces attached to the core network must be running MPLS, the same label distribution protocol, and the same IPv4 IGP, as in the core network.
- The 6PE routers must also be configured to be dual stack to run both IPv4 and IPv6.



Note



Note

As of Cisco IOS Release 12.2(22)S, the following restrictions do not apply to Cisco IOS 12.2S

The following restrictions apply when implementing the IPv6 Provider Edge Router over MPLS (6PE) feature:

- Core MPLS routers are supporting MPLS and IPv4 only, so they cannot forward or create any IPv6 Internet Control Message Protocol (ICMP) messages.
- Load balancing ability is not provided by Cisco 6PE between an MPLS path and an IPv6 path. If both are available, the MPLS path is always preferred. Load balancing between two MPLS paths is possible.
- BGP multipath is not supported for Cisco 6PE routes. If two BGP peers advertise the same prefix with an equal cost, Cisco 6PE will use the last route to cross the MPLS core.
- 6PE feature is not supported over tunnels other than RSVP-TE tunnels.

>

## SUMMARY STEPS

1. **enable**
2. **configure terminal**
3. **ipv6 unicast-routing**
4. **ipv6 cef**
5. **interface** *type number*
6. **ipv6 address** *ipv6-address / prefix-length | prefix-name sub-bits / prefix-length*

## DETAILED STEPS

Command or Action	Purpose
<b>Step 1 enable</b>  <b>Example:</b> Router> enable	Enables privileged EXEC mode. <ul style="list-style-type: none"> <li>• Enter your password if prompted.</li> </ul>
<b>Step 2 configure terminal</b>  <b>Example:</b> Router# configure terminal	Enters global configuration mode.

Command or Action	Purpose
<b>Step 3</b> <b>ipv6 unicast-routing</b>  <b>Example:</b> <pre>Router(config)# ipv6 unicast-routing</pre>	Enables the forwarding of IPv6 unicast datagrams.
<b>Step 4</b> <b>ipv6 cef</b>  <b>Example:</b> <pre>Router(config)# ipv6 cef</pre>	Enables IPv6 Cisco Express Forwarding.
<b>Step 5</b> <b>interface type number</b>  <b>Example:</b> <pre>Router(config)# interface Serial 0/0</pre>	Specifies an interface type and number and enters interface configuration mode. <ul style="list-style-type: none"> <li>In the context of this feature, the interface to be configured is the interface communicating with the CE router.</li> </ul>
<b>Step 6</b> <b>ipv6 address ipv6-address / prefix-length   prefix-name sub-bits / prefix-length</b>  <b>Example:</b> <pre>Router(config-if)# ipv6 address 2001:DB8:FFFF::2/64</pre>	Configures an IPv6 address based on an IPv6 general prefix and enable IPv6 processing on an interface.

## Binding and Advertising the 6PE Label to Advertise Prefixes

Perform this task to enable the binding and advertising of aggregate labels when advertising IPv6 prefixes to a specified BGP neighbor.

### SUMMARY STEPS

- enable**
- configure terminal**
- router bgp** *as-number*
- no bgp default ipv4-unicast**
- neighbor** {*ip-address* | *ipv6-address* | *peer-group-name*} **remote-as** *as-number*
- neighbor** *ip-address* | *ipv6-address* | *peer-group-name*} **update-source** *interface-type interface-number*
- address-family ipv6** [**unicast**]
- neighbor** {*ip-address* | *peer-group-name* | *ipv6-address*} **activate**
- neighbor** {*ip-address* | *ipv6-address*} **send-label**

## DETAILED STEPS

Command or Action	Purpose
<p><b>Step 1</b> <code>enable</code></p> <p><b>Example:</b></p> <pre>Router&gt; enable</pre>	<p>Enables privileged EXEC mode.</p> <ul style="list-style-type: none"> <li>Enter your password if prompted.</li> </ul>
<p><b>Step 2</b> <code>configure terminal</code></p> <p><b>Example:</b></p> <pre>Router# configure terminal</pre>	<p>Enters global configuration mode.</p>
<p><b>Step 3</b> <code>router bgp <i>as-number</i></code></p> <p><b>Example:</b></p> <pre>Router(config)# router bgp 65000</pre>	<p>Enters router configuration mode for the specified routing process.</p>
<p><b>Step 4</b> <code>no bgp default ipv4-unicast</code></p> <p><b>Example:</b></p> <pre>Router(config-router)# no bgp default ipv4-unicast</pre>	<p>Disables the IPv4 unicast address family for the BGP routing process specified in the previous step.</p> <p><b>Note</b> Routing information for the IPv4 unicast address family is advertised by default for each BGP routing session configured with the <b>neighbor remote-as</b> command unless you configure the <b>no bgp default ipv4-unicast</b> command before configuring the <b>neighbor remote-as</b> command.</p>
<p><b>Step 5</b> <code>neighbor {<i>ip-address</i>   <i>ipv6-address</i>   <i>peer-group-name</i>} remote-as <i>as-number</i></code></p> <p><b>Example:</b></p> <pre>Router(config-router)# neighbor 192.168.99.70 remote-as 65000</pre>	<p>Adds the IP address of the neighbor in the specified autonomous system to the BGP neighbor table of the local router.</p>
<p><b>Step 6</b> <code>neighbor <i>ip-address</i>   <i>ipv6-address</i>   <i>peer-group-name</i> update-source <i>interface-type interface-number</i></code></p> <p><b>Example:</b></p> <pre>Router(config-router)# neighbor 192.168.99.70 update-source Loopback 0</pre>	<p>Specifies the interface whose IPv4 address is to be used as the source address for the peering.</p> <ul style="list-style-type: none"> <li>In the context of this task, the interface must have an IPv4 address with a 32-bit mask configured. Use of a loopback interface is recommended. This address is used to determine the IPv6 next hop by the peer 6PE.</li> </ul>



Command or Action	Purpose
<p><b>Step 7</b> <code>address-family ipv6 [unicast]</code></p> <p><b>Example:</b></p> <pre>Router(config-router)# address-family ipv6</pre>	<p>Specifies the IPv6 address family and enters address family configuration mode.</p> <ul style="list-style-type: none"> <li>The <b>unicast</b> keyword specifies the IPv6 unicast address family. By default, the router is placed in configuration mode for the IPv6 unicast address family if the <b>unicast</b> keyword is not specified with the <b>address-family ipv6</b> command.</li> </ul>
<p><b>Step 8</b> <code>neighbor {ip-address   peer-group-name   ipv6-address} activate</code></p> <p><b>Example:</b></p> <pre>Router(config-router-af)# neighbor 192.168.99.70 activate</pre>	<p>Enables the neighbor to exchange prefixes for the IPv6 address family with the local router.</p>
<p><b>Step 9</b> <code>neighbor {ip-address   ipv6-address} send-label</code></p> <p><b>Example:</b></p> <pre>Router(config-router-af)# neighbor 192.168.99.70 send-label</pre>	<p>Advertises the capability of the router to send MPLS labels with BGP routes.</p> <ul style="list-style-type: none"> <li>In IPv6 address family configuration mode this command enables binding and advertisement of aggregate labels when advertising IPv6 prefixes in BGP.</li> </ul>

## Configuring iBGP Multipath Load Sharing

Perform this task to configure iBGP multipath load sharing and control the maximum number of parallel iBGP routes that can be installed in a routing table.

### SUMMARY STEPS

1. **enable**
2. **configure terminal**
3. **router bgp** *as-number*
4. **maximum-paths ibgp** *number-of-paths*

### DETAILED STEPS

Command or Action	Purpose
<p><b>Step 1</b> <code>enable</code></p> <p><b>Example:</b></p> <pre>Router&gt; enable</pre>	<p>Enables privileged EXEC mode.</p> <ul style="list-style-type: none"> <li>Enter your password if prompted.</li> </ul>

Command or Action	Purpose
<b>Step 2</b> <b>configure terminal</b>  <b>Example:</b> <pre>Router# configure terminal</pre>	Enters global configuration mode.
<b>Step 3</b> <b>router bgp as-number</b>  <b>Example:</b> <pre>Router(config)# router bgp 65000</pre>	
<b>Step 4</b> <b>maximum-paths ibgp number-of-paths</b>  <b>Example:</b> <pre>Router(config-router)# maximum-paths ibgp 3</pre>	

## Verifying 6PE Configuration and Operation

When 6PE is running, the following components can be monitored:

- Multiprotocol BGP
- MPLS
- Cisco Express Forwarding for IPv6
- IPv6 routing table

### SUMMARY STEPS

1. **show bgp ipv6** {unicast | multicast} [ipv6-prefix / prefix-length] [longer-prefixes] [labels]
2. **show bgp ipv6** {unicast | multicast} neighbors [ipv6-address] [received-routes | routes | flap-statistics | advertised-routes | paths regular-expression | dampened-routes]
3. **show mpls forwarding-table** [network {mask | length}] [labels label[- label]] | **interface** interface | **nexthop** address | **lsp-tunnel** [tunnel-id] | [vrf vrf-name] [detail]
4. **show ipv6 cef** [ipv6-prefix / prefix-length] | [interface-type interface-number] [longer-prefixes | similar-prefixes | detail | internal | platform | epoch | source]
5. **show ipv6 route** [ipv6-address | ipv6-prefix / prefix-length | protocol | interface-type interface-number]

## DETAILED STEPS

Command or Action	Purpose
<p><b>Step 1</b> <code>show bgp ipv6 {unicast   multicast} [ipv6-prefix / prefix-length] [longer-prefixes] [labels]</code></p> <p><b>Example:</b></p> <pre>Router&gt; show bgp ipv6 unicast 2001:DB8:DDDD::/48</pre>	<p>(Optional) Displays entries in the IPv6 BGP routing table.</p> <ul style="list-style-type: none"> <li>In this example, information about the IPv6 route for the prefix 2001:DB8:DDDD::/48 is displayed.</li> </ul>
<p><b>Step 2</b> <code>show bgp ipv6 {unicast   multicast} neighbors [ipv6-address] [received-routes   routes   flap-statistics   advertised-routes   paths regular-expression   dampened-routes]</code></p> <p><b>Example:</b></p> <pre>Router&gt; show bgp ipv6 neighbors unicast 192.168.99.70</pre>	<p>(Optional) Displays information about IPv6 BGP connections to neighbors.</p> <ul style="list-style-type: none"> <li>In this example, information including the IPv6 label capability is displayed for the BGP peer at 192.168.99.70.</li> </ul>
<p><b>Step 3</b> <code>show mpls forwarding-table [network{mask  length}] labels label[- label]   interface interface  nexthop address  lsp-tunnel[tunnel-id]] [vrf vrf-name] [detail]</code></p> <p><b>Example:</b></p> <pre>Router&gt; show mpls forwarding-table</pre>	<p>(Optional) Displays the contents of the MPLS Forwarding Information Base (FIB).</p> <ul style="list-style-type: none"> <li>In this example, information linking the MPLS label with IPv6 prefixes is displayed where the labels are shown as aggregate and the prefix is shown as IPv6.</li> </ul>
<p><b>Step 4</b> <code>show ipv6 cef [ipv6-prefix / prefix-length]   [interface-type interface-number] [longer-prefixes   similar-prefixes   detail   internal   platform   epoch   source]]</code></p> <p><b>Example:</b></p> <pre>Router&gt; show ipv6 cef 2001:DB8:DDDD::/64</pre>	<p>(Optional) Displays FIB entries based on IPv6 address information.</p> <ul style="list-style-type: none"> <li>In this example, label information from the Cisco Express Forwarding table for prefix 2001:DB8:DDDD::/64 is displayed.</li> </ul>
<p><b>Step 5</b> <code>show ipv6 route [ipv6-address   ipv6-prefix / prefix-length   protocol   interface-type interface-number]</code></p> <p><b>Example:</b></p> <pre>Router&gt; show ipv6 route</pre>	<p>(Optional) Displays the current contents of the IPv6 routing table.</p>

- [Output Examples, page 11](#)

## Output Examples

### Sample Output from the show bgp ipv6 Command

This example shows output information about an IPv6 route using the **show bgp ipv6** command with an IPv6 prefix:

```
Router# show bgp ipv6 2001:DB8:DDDD::/48
BGP routing table entry for 2001:DB8:DDDD::/48, version 15
Paths: (1 available, best #1, table Global-IPv6-Table)
  Not advertised to any peer
  Local
    ::FFFF:192.168.99.70 (metric 20) from 192.168.99.70 (192.168.99.70)
      Origin IGP, localpref 100, valid, internal, best
```

### Sample Output from the show bgp ipv6 neighbors Command

This example shows output information about a BGP peer, including the "IPv6 label" capability, using the **show bgp ipv6 neighbors** command with an IP address:

```
Router# show bgp ipv6 neighbors 192.168.99.70
BGP neighbor is 192.168.99.70, remote AS 65000, internal link
  BGP version 4, remote router ID 192.168.99.70
  BGP state = Established, up for 00:05:17
  Last read 00:00:09, hold time is 0, keepalive interval is 60 seconds
  Neighbor capabilities:
    Route refresh: advertised and received
    Address family IPv6 Unicast: advertised and received
    ipv6 MPLS Label capability: advertised and received
  Received 54 messages, 0 notifications, 0 in queue
  Sent 55 messages, 1 notifications, 0 in queue
  Default minimum time between advertisement runs is 5 seconds
  For address family: IPv6 Unicast
  BGP table version 21880, neighbor version 21880
  Index 1, Offset 0, Mask 0x2
  Route refresh request: received 0, sent 0
  77 accepted prefixes consume 4928 bytes
  Prefix advertised 4303, suppressed 0, withdrawn 1328
  Number of NLRI in the update sent: max 1, min 0
```

### Sample Output from the show mpls forwarding-table Command

This example shows output information linking the MPLS label with prefixes using the **show mpls forwarding-table** command. If the 6PE feature is configured, the labels are aggregated because there are several prefixes for one local label, and the prefix column contains "IPv6" instead of a target prefix.

```
Router# show mpls forwarding-table
Local Outgoing Prefix Bytes tag Outgoing Next Hop
tag tag or VC or Tunnel Id switched interface
16 Aggregate IPv6 0
17 Aggregate IPv6 0
18 Aggregate IPv6 0
19 Pop tag 192.168.99.64/30 0 Se0/0 point2point
20 Pop tag 192.168.99.70/32 0 Se0/0 point2point
21 Pop tag 192.168.99.200/32 0 Se0/0 point2point
22 Aggregate IPv6 5424
23 Aggregate IPv6 3576
24 Aggregate IPv6 2600
```

### Sample Output from the show bgp ipv6 Command

This example shows output information about the top of the stack label with label switching information using the **show bgp ipv6** command with the **labels** keyword:

```
Router# show bgp ipv6 labels
Network Next Hop In tag/Out tag
2001:DB8:DDDD::/64 ::FFFF:192.168.99.70 notag/20
```

### Sample Output from the show ipv6 cef Command

This example shows output information about labels from the Cisco Express Forwarding table using the **show ipv6 cef** command with an IPv6 prefix:

```
Router# show ipv6 cef 2001:DB8:DDDD::/64
2001:DB8:DDDD::/64
  nexthop ::FFFF:192.168.99.70
  fast tag rewrite with Se0/0, point2point, tags imposed {19 20}
```

### Sample Output from the show ipv6 route Command

This example shows output information from the IPv6 routing table using the **show ipv6 route** command. The output shows the IPv6 MPLS virtual interface as the output interface of IPv6 routes forwarded across the MPLS cloud. In this example using the routers in the figure above, the output is from the 6PE1 router.

The 6PE2 router has advertised the IPv6 prefix of 2001:DB8:dddd::/48 configured for the CE2 router and the next-hop address is the IPv4-compatible IPv6 address ::ffff:192.168.99.70, where 192.168.99.70 is the IPv4 address of the 6PE2 router.

```
Router# show ipv6 route
IPv6 Routing Table - 10 entries
Codes: C - Connected, L - Local, S - Static, R - RIP, B - BGP
I1 - ISIS L1, I2 - ISIS L2, IA - ISIS interarea
B 2001:DB8:DDDD::/64 [200/0]
  via ::FFFF:192.168.99.70, IPv6-mpls
B 2001:DB8:DDDD::/64 [200/0]
  via ::FFFF:192.168.99.70, IPv6-mpls
L 2001:DB8:FFFF::1/128 [0/0]
  via ::, Ethernet0/0
C 2001:DB8:FFFF::/64 [0/0]
  via ::, Ethernet0/0
S 2001:DB8:FFFF::/48 [1/0]
  via 2001:DB8:B00:FFFF::2, Ethernet0/0
```

## Configuration Examples for IPv6 over MPLS

The following examples show 6PE configuration examples for three of the routers shown in the figure above and used in the [Specifying the Source Address Interface on a 6PE Router, page 5](#) and [Binding and Advertising the 6PE Label to Advertise Prefixes, page 7](#) sections.

- [Example Customer Edge Router, page 13](#)
- [Example Provider Edge Router, page 14](#)
- [Example Core Router, page 15](#)

### Example Customer Edge Router

This example shows that the serial interface 0/0 of the customer edge router--CE1 in the figure above--is connected to the service provider and is assigned an IPv6 address. IPv6 is enabled and a default static route is installed using the IPv6 address of serial interface 0/0 of the 6PE1 router.

```
ip cef
!
ipv6 unicast-routing
!
interface Serial 0/0
  description to_6PE1_router
  no ip address
  ipv6 address 2001:DB8:FFFF::2/64
```

```
!
ipv6 route ::/0 Serial 0/0 FE80::210:XXXX:FEE1:1001
```

## Example Provider Edge Router

The 6PE router--Router 6PE1 in the figure above--is configured for both IPv4 and IPv6 traffic. Ethernet interface 0/0 is configured with an IPv4 address and is connected to a router in the core of the network--router P1 in the figure above. Integrated IS-IS and TDP configurations on this router are similar to the P1 router.

Router 6PE1 exchanges IPv6 routing information with another 6PE router--Router 6PE2 in the figure above-- using internal BGP (iBGP) established over an IPv4 connection so that all the **neighbor** commands use the IPv4 address of the 6PE2 router. All the BGP peers are within autonomous system 65000, so synchronization with IGP is turned off for IPv4. In IPv6 address family configuration mode, synchronization is disabled by default.

IPv6 and Cisco Express Forwarding for IPv6 are enabled, the 6PE2 neighbor is activated, and aggregate label binding and advertisement is enabled for IPv6 prefixes using the **neighbor send-label** command. Connected and static IPV6 routes are redistributed using BGP. If IPv6 packets are generated in the local router, the IPv6 address for MPLS processing will be the address of loopback interface 0.

This example shows that the serial interface 0/0 connects to the customer and the IPv6 prefix delegated to the customer is 2001:DB8:ffff::/48, which is determined from the service provider IPv6 prefix. A static route is configured to route IPv6 packets between the 6PE router and the CE router.

```
ip cef
ipv6 cef
ipv6 unicast-routing
!
mpls ipv6 source-interface Loopback0
tag-switching tdp router-id Loopback0
!
interface Loopback0
 ip address 192.168.99.5 255.255.255.255
 ipv6 address 2001:DB8:1000:1::1/64
!
interface Ethernet0/0
 description to_P_router
 ip address 192.168.99.1 255.255.255.252
 ip router isis
 tag-switching ip
!
interface Serial0/0
 description to_CE_router
 no ip address
 ipv6 address 2001:DB8:FFFF::1/64
!
router isis
 passive-interface Loopback0
 net 49.0001.1921.6809.9005.00
!
router bgp 65000
 no bgp default ipv4-unicast
 bgp log-neighbor-changes
 neighbor 192.168.99.70 remote-as 65000
 neighbor 192.168.99.70 description to_6PE2
 neighbor 192.168.99.70 update-source Loopback0
!
 address-family ipv6
 neighbor 192.168.99.70 activate
 neighbor 192.168.99.70 send-label
 network 2001:DB8:FFFF::/48
 exit-address-family
!
ipv6 route 2001:DB8:FFFF::/48 Ethernet0/0 2001:DB8:FFFF::2
```

以上内容仅为本文档的试下载部分，为可阅读页数的一半内容。如要下载或阅读全文，请访问：<https://d.book118.com/327041134051006041>